

outdoor KITCHEN + UNIT

CUCINE DA ESTERNO E PIANI COTTURA . L'ECCELLENZA DELL'ACCIAIO INOX

—
Outdoor Kitchens and Cooktops . The Excellence of Stainless Steel
Cuisines d'extérieur et plans de cuisson . L'excellence de l'acier inoxydable
Außenküchen und Kochfelder . Die Exzellenz von Edelstahl

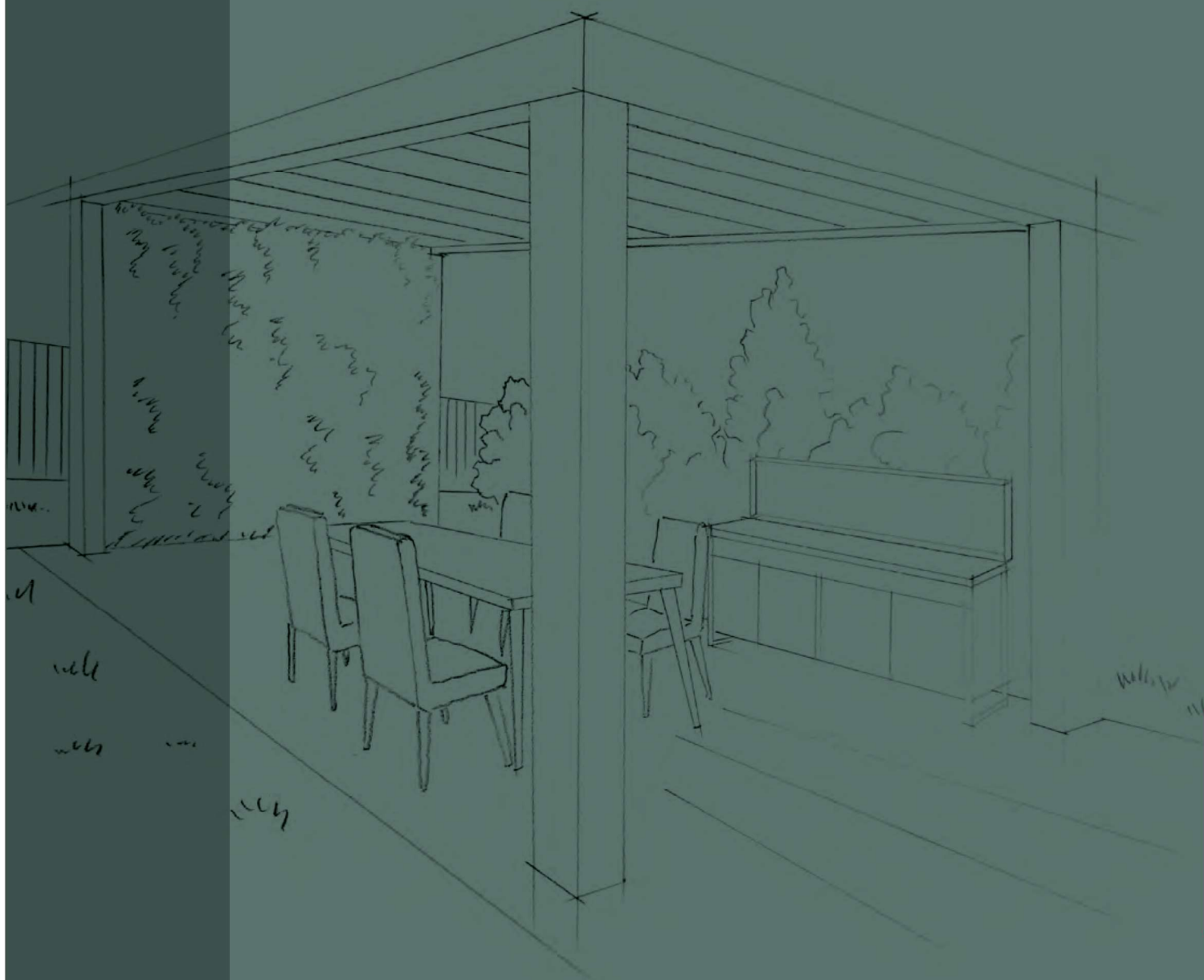

Since 2005

Dove arrivano

Qualità e Bellezza

con PLA.NET?

Ovunque, i nostri prodotti garantiscono prestazioni di alto livello, scrivendo ogni giorno una nuova pagina nella storia di successo di PLA.NET

Where do **quality and beauty** converge with PLA.NET?

Everywhere. Our products ensure high performance, shaping a new chapter in PLA.NET success story every day.

LEVIGMATIC è professional cooking

Stabilimento operativo dal 1988, specializzato nella produzione di piani cottura in acciaio destinati alla ristorazione professionale.

Per i più rinomati marchi della ristorazione professionale:

- rappresenta lo SPECIALISTA dei piani cottura
- lavora 10 tipi di ACCIAIO in diversi spessori
- esporta in 5 CONTINENTI e 24 NAZIONI
- dispone di 2 UNITÀ PRODUTTIVE a Conegliano Veneto (Italia):

LEVIGMATIC professional cooking

Since 1988, our company has been producing stainless steel cooktops for professional kitchens.

We work with the most renowned catering brands:

- we are recognized as the SPECIALIST in cooktops
- we process 10 types of STAINLESS STEEL in different thicknesses
- we export to 5 CONTINENTS and 24 COUNTRIES
- we have two PRODUCTION FACILITIES in Conegliano Veneto (Italy)

LEVIGMATIC professional cooking

En activité depuis 1988, notre entreprise est spécialisée dans la fabrication de plans de cuisson en acier inoxydable pour la restauration professionnelle.

Nous travaillons pour les marques les plus réputées de la restauration:

- nous sommes reconnus comme SPECIALISTE des plans de cuisson
- nous travaillons 10 types d'ACIER INOXYDABLE de différentes épaisseurs
- nous exportons vers 5 CONTINENTS et 24 PAYS
- nous disposons de 2 unités de production à Conegliano Veneto (Italie)

LEVIGMATIC professional cooking

Seit 1988 tätig, ist unser Unternehmen auf die Herstellung von Edelstahlkochfeldern für die professionelle Gastronomie spezialisiert.

Wir arbeiten mit den renommiertesten Marken der Profiküche zusammen:

- Wir sind als SPEZIALIST für Kochfelder anerkannt
- Wir verarbeiten 10 EDELSTAHLARTEN in verschiedenen Stärken
- Wir exportieren auf 5 KONTINENTE in 24 LÄNDER
- Wir verfügen über zwei PRODUKTIONSSTÄTTEN in Conegliano Veneto (Italien)



PRODUCTION UNIT 1 - 2400 mq / 2,400 sq m

Ciclo completo produzione piastre cottura professionali.
Full production cycle of professional cooking plates.

Cycle complet de production de plaques de cuisson professionnelles.
Kompletter Produktionszyklus für professionelle Kochplatten.



PRODUCTION UNIT 2 - 2600 mq / 2,600 sq m

Ciclo completo produzione e assemblaggio collezione PLA.NET
Complete production and assembly of the PLA.NET collection

Production et assemblage complets de la collection PLA.NET
Kompletter Produktions- und Montagezyklus der PLA.NET Kollektion

professional
cooking

levigmatic

PLA.NET® è outdoor cooking

è un progetto nato nel 2005,

è un marchio registrato di Levigmatic Srl

è interamente disegnato e prodotto in Italia

Dedicato a chi vuole cucinare a casa, all'esterno:

- in modo SEMPLICE e in buona compagnia
- una grande VARIETÀ DI CIBO, GUSTOSO e SENZA FUMO
- rispettando L'AMBIENTE e la SALUTE

Con prodotti in Acciaio Inox alimentare (A.304 L):

- con funzionamento a GAS o ELETTRICI
- testati e certificati da IMQ Spa e TUV GmbH

PLA.NET® outdoor cooking

conceived in 2005

a registered trademark of Levigmatic Srl

entirely designed and made in Italy

Designed for those who love to cook at home and in the open air:

- in a SIMPLE way and in great company
- with a wide VARIETY OF DISHES, always DELICIOUS and SMOKE-FREE
- fully respecting the ENVIRONMENT and HEALTH

All our products are made of (AISI 304 L) food-grade stainless steel

- available in GAS or ELECTRIC versions
- tested and certified by IMQ Spa and TUV GmbH

PLA.NET® outdoor cooking

créée en 2005

marque déposée de Levigmatic Srl

entièrement conçu et fabriqué en Italie

Pour ceux qui aiment cuisiner à la maison et en plein air:

- d'une manière SIMPLE et en bonne compagnie
- avec une grande VARIÉTÉ D'ALIMENTS, toujours DELICIEUX et SANS FUMÉE
- dans le plein respect de l'ENVIRONNEMENT et de la SANTÉ

Tous nos produits sont fabriqués en acier inoxydable alimentaire (AISI 304 L)

- disponibles en versions GAZ ou ELECTRIQUE
- testés et certifiés par IMQ Spa et TUV GmbH

PLA.NET® outdoor cooking

gegründet 2005

eingetragene Marke der Levigmatic Srl

vollständig in Italien entworfen und hergestellt

Für alle, die das Kochen zu Hause und im Freien lieben:

- in aller EINFACHHEIT Weise und in guter Gesellschaft
- mit einer großen SPEISENVIELFALT, immer LECKER und RAUCHFREI
- völlig im Einklang mit der UMWELT und der GESUNDHEIT

Alle unsere Produkte bestehen aus lebensmittelechtem Edelstahl (AISI 304 L)

- Erhältlich als GAS- oder ELEKTRO-Version
- Geprüft und zertifiziert von IMQ Spa und TÜV GmbH

outdoor
cooking



Qualità e Bellezza

fanno molta strada con PLA.NET,
arrivando ovunque ci sia un
desiderio da realizzare.

Quality and beauty
set the pace for PLA.NET,
arriving wherever a dream comes to life.

Project in **VENICE** Italy

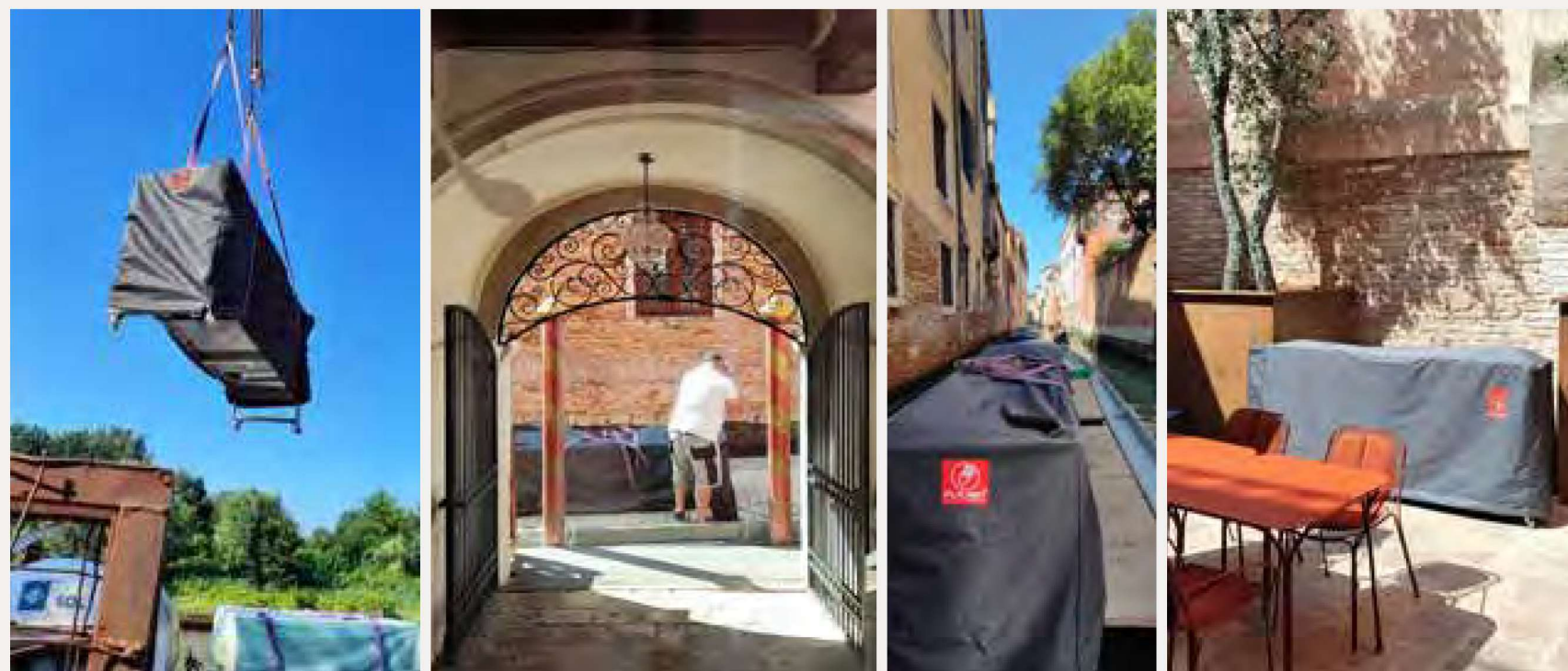

OASI

collection



Textured
Black



Inox/PB



Inox/PM



Inox/PB



Inox/PM

205.D
95.ICE

183.D
142.D
95.D

Con Oasi collection la cucina outdoor é versatile: una gamma di quattro misure disponibili, con piano cottura a scelta tra top unico o più elementi componibili. Disponibile in inox o nelle varianti verniciate.

The Oasi Collection brings versatility to outdoor cooking. Available in four sizes, it offers a choice between a seamless worktop or various modular units. Available in stainless steel or a selection of powder-coated finishes

La collection Oasi apporte une grande modularité à la cuisine d'extérieur: disponible en quatre dimensions, elle permet de choisir entre un plan de travail sans joints ou plusieurs éléments

modulables. Disponible en acier inoxydable ou en finitions thermolaquées (peintes).

Mit der Kollektion Oasi wird die Outdoor-Küche vielseitig: in vier verfügbaren Größen haben Sie die Wahl zwischen einer nahtlosen Arbeitsplatte oder flexiblen Kombinationselementen. Verfügbar in Edelstahl oder in verschiedenen pulverbeschichteten Farbvarianten

Kitchen
205.D T

Madia
Sideboard / Buffet / Sideboard
M.90 (x2)

Finitura
Finish / Finition / Ausführung
Textured Black

design | Marco De Luca . Francesco Massimo

OASI

COPERCHIO UNICO

One-piece full Lid
Couvercle unique
Einteiliger Gesamtdeckel



MENSOLA LATERALE PIEGHEVOLE

Foldable side shelf
Étagère latérale rabattable
Klappbare Seitenablage



APERTURA ANTE

Door Opening
Ouverture des portes
Türöffnung



< PIANO A INDUZIONE E PIASTRA ELETTRICA

Induction hob and electric
cooking plate
Plaque à induction et Plaque
de cuisson électrique
Induktionskochfeld und
Elektro-Grillplatte

OASI

205.D T

L 205 x P 56+7 x H 87 cm

135 Kg

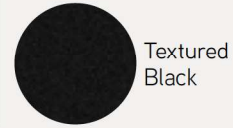

Textured Black



PIANO CUCINA: TOP UNICO

WORKTOP: SEAMLESS WORKTOP | PLAN DE TRAVAIL: PLAN DE TRAVAIL SANS JOINTS | ARBEITSPLATTE: NAHTLOSE ARBEITSPLATTE

Coperchio in Acciaio Inox verniciato Black
Black powder-coated stainless steel lid
Couvercle en acier inoxydable thermolaqué noir
Pulverbeschichteter schwarzer Edelstahldeckel

4 ante in Acciaio Inox verniciato Black con Easy Stop
4 black powder-coated stainless steel doors with Easy-Stop system
4 portes en acier inoxydable thermolaqué noir avec système Easy-Stop
4 pulverbeschichtete schwarze Edelstahltüren mit Easy-Stop-System

Gambe Inox con piedini regolabili, predisposti per utilizzo kit ruote
Stainless steel legs with adjustable feet, pre-drilled for wheel kit installation.
Pieds en acier inoxydable avec patins réglables, prédisposés pour l'installation d'un kit de roues.
Edelstahlbeine mit verstellbaren Füßen, vorgebohrt für die Montage eines Rollensatzes.

Top unico in Acciaio Inox disponibile in più combinazioni di elementi cottura e lavaggio, sia a gas che elettrico
Seamless stainless steel worktop, available in multiple layouts for cooking and washing elements, both gas and electric.
Plan de travail sans joints en acier inoxydable, disponible en plusieurs combinaisons d'éléments de cuisson et de lavage, en version gaz ou électrique.
Nahtlose Edelstahl-Arbeitsplatte, erhältlich in verschiedenen Kombinationen aus Koch- und Spülelementen, sowohl in Gas- als auch in Elektroausführung.

COMPOSIZIONI TOP DISPONIBILI

AVAILABLE WORKTOP LAYOUTS | CONFIGURATIONS DES PLANS DISPONIBLES | VERFÜGBARE ARBEITSPLATTEN-KOMBINATIONEN



GAS



ELECTRIC

T2

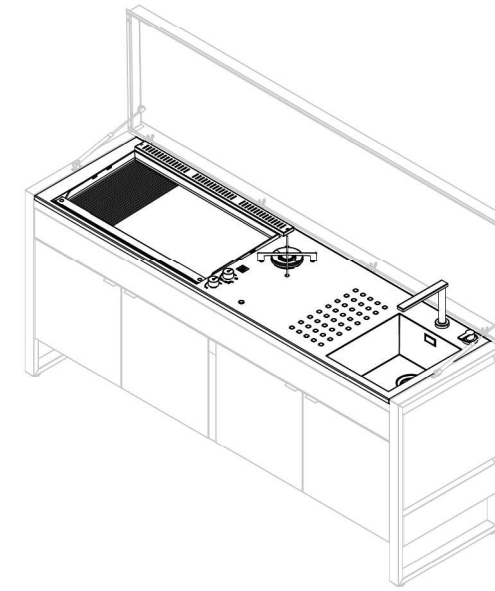

T7

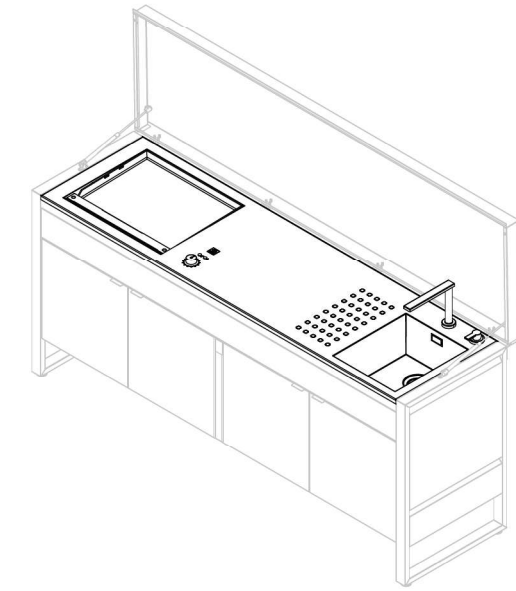

T26

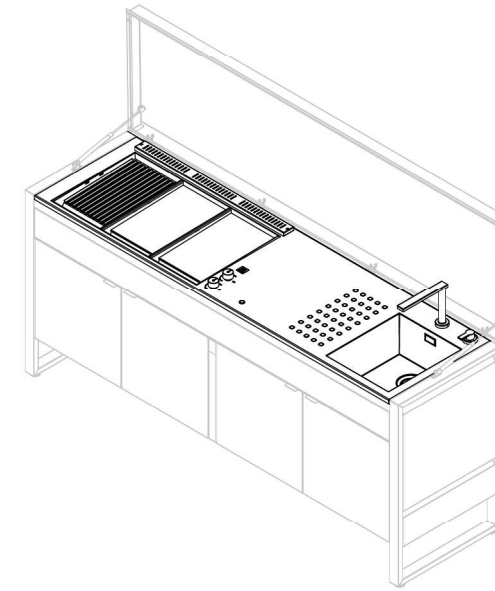

T8

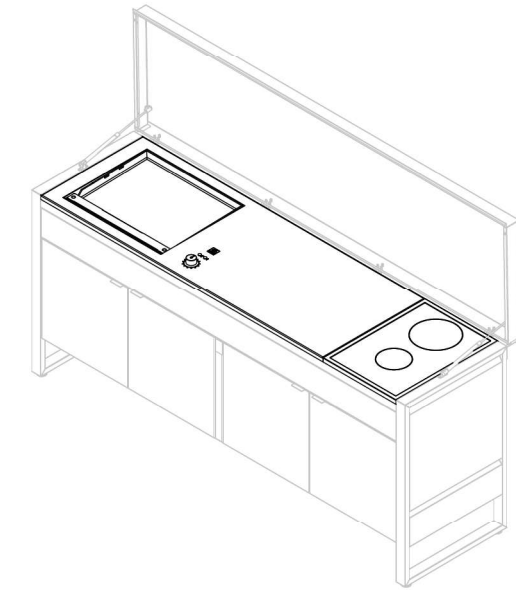

T4

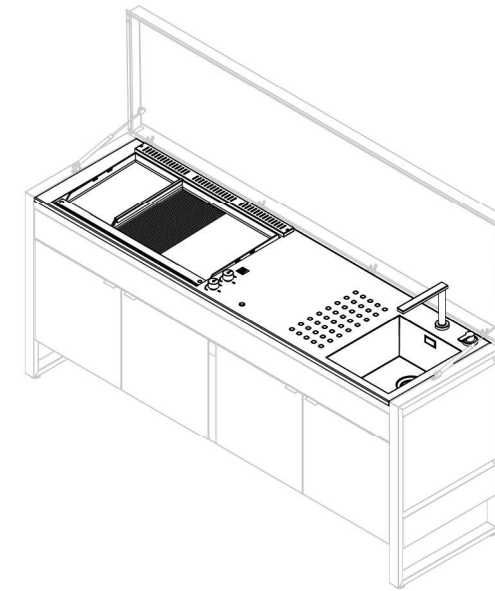

T9

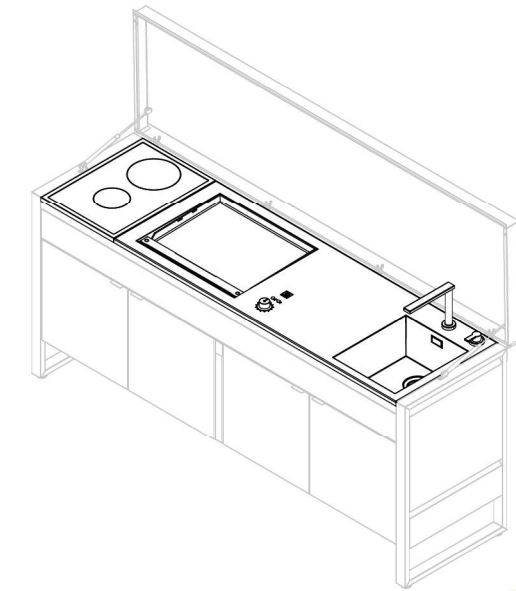

OASI

205.D

L 205 x P 56+7 x H 87 cm

135 Kg

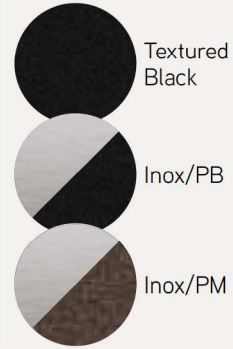

PIANO CUCINA: TOP COMPONENTE

KITCHEN WORKTOP: MODULAR WORKTOP | PLAN DE CUISINE: PLAN DE TRAVAIL MODULABLE | KÜCHENARBEITSPLATTE: MODULARE ARBEITSPLATTE

Coperchio e fascia in Inox verniciati Black o Moka
Lid and fascias in black or moka powder-coated stainless steel
Couvercle et bandeau en acier inoxydable thermolaqué noir ou moka
Deckel und Leisten aus Edelstahl, schwarz oder moka pulverbeschichtet

4 ante in Acciaio Inox con Easy Stop
4 stainless steel doors with Easy-Stop system
4 portes en acier inoxydable avec système Easy-Stop
4 Edelstahltüren mit Easy-Stop-System

Gambe Inox con piedini regolabili, predisposti per utilizzo kit ruote
Stainless steel legs with adjustable feet, pre-drilled for wheel kit installation
Pieds en acier inoxydable avec patins réglables, prédisposés pour l'installation d'un kit de roues.
Edelstahlbeine mit verstellbaren Füßen, vorbereitet für die Montage eines Radsatzes



Top in Acciaio Inox personalizzabile con una vasta gamma di piani cottura, fornelli a gas o elettrici, da completare con lavello e piani di lavoro
Stainless steel worktop, customizable with a wide range of cooking plates, gas or electric burners, to be completed with sink units and work surfaces.
Plan de travail en acier inoxydable personnalisable avec une large gamme de plaques de cuisson, feux à gaz ou électriques, à compléter avec évier et plans de travail.
Individuell gestaltbare Edelstahl-Arbeitsplatte mit einer großen Auswahl an Kochelementen, Gas- oder Elektroherden, ergänzbar durch Spülbecken und Arbeitsflächen.

COMPOSIZIONI TOP DISPONIBILI

AVAILABLE WORKTOP LAYOUTS | CONFIGURATIONS DES PLANS DISPONIBLES | VERFÜGBARE ARBEITSPLATTEN-KOMBINATIONEN



01

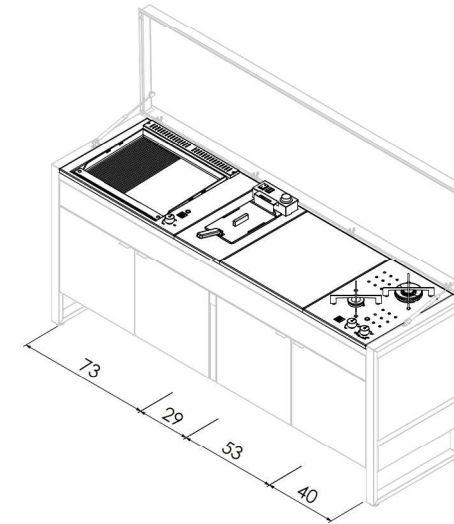

02

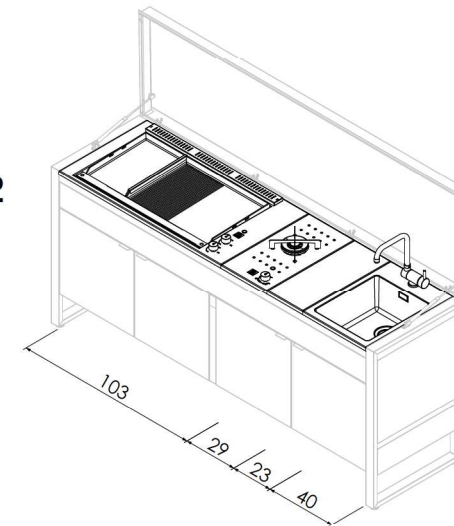

03

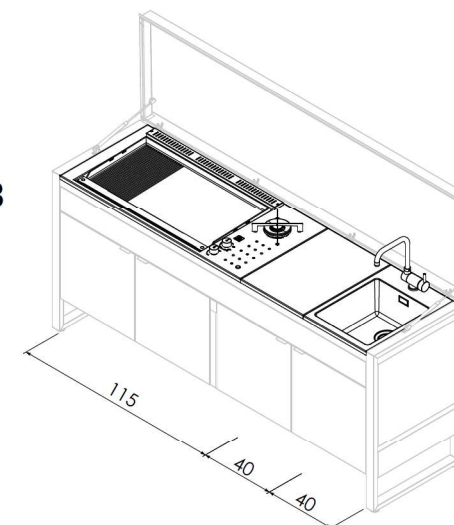

06

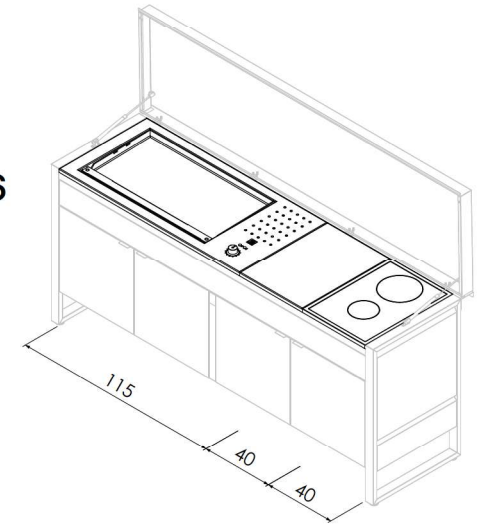

07

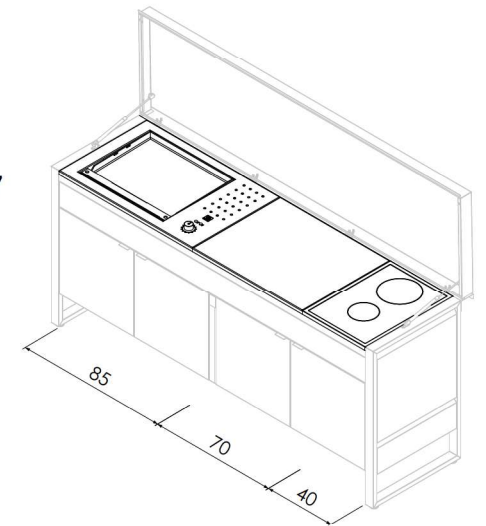

08

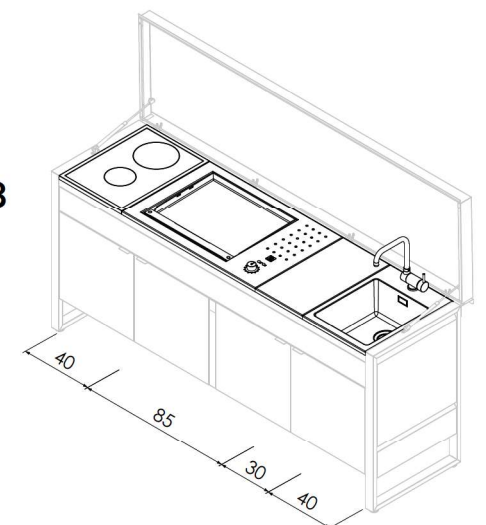

OASI

Kitchen
183.D + 95ICE
Finitura
Finish / Finition / Ausführung
Inox PB

OASI

CLOCHE Coperchio inox per cottura indiretta

Couvercle pour cuisson
avec thermomètre
Cooking lid with thermometer
Kochdeckel mit Thermometer

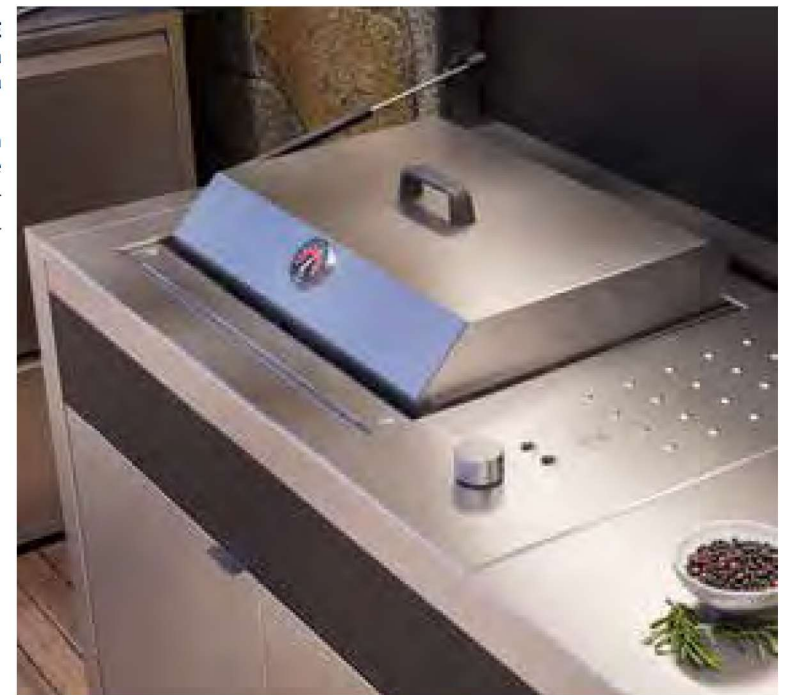

PIANO A INDUZIONE

Induction hob
Plaque à induction
Induktionskochfeld



RUBINETTO MISCELATORE ABBATTIBILE

Retractable Mixer Tap
Robinet Mélangeur pliable
faltbarer Spülbecken-
Mischbatterie



< Kitchen
95.D
Finitura
Finish / Finition / Ausführung
Inox PB

OASI

183.D

L 183 x P 56+7 x H 87 cm

120 Kg

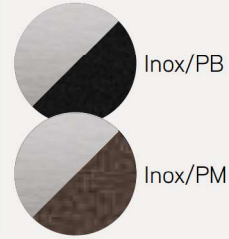

PIANO CUCINA: TOP COMPONENTE

KITCHEN WORKTOP: MODULAR WORKTOP | PLAN DE CUISINE: PLAN DE TRAVAIL MODULABLE | KÜCHENARBEITSPLATTE: MODULARE ARBEITSPLATTE

Coperchio e fascia in Inox verniciati Black o Moka
Lid and fascias in black or moka powder-coated stainless steel
Couvercle et bandeau en acier inoxydable thermolaqué noir ou moka
Deckel und Leisten aus Edelstahl, schwarz oder moka pulverbeschichtet

2 ante in Inox con Easy Stop e pannello centrale fisso
2 stainless steel doors with Easy-Stop system and fixed central panel
2 portes en acier inoxydable avec système Easy-Stop et panneau central fixe
2 Edelstahltüren mit Easy-Stop-System und festem Mittelpaneel

Gambe Inox con piedini regolabili, predisposti per utilizzo kit ruote
Stainless steel legs with adjustable feet, pre-drilled for wheel kit installation
Pieds en acier inoxydable avec patins réglables, prédisposés pour l'installation d'un kit de roues.
Edelstahlbeine mit verstellbaren Füßen, vorbereitet für die Montage eines Radsatzes

Top in Acciaio Inox personalizzabile con una vasta gamma di piani cottura, fornelli a gas o elettrici, da completare con lavello e piani di lavoro

Stainless steel worktop, customizable with a wide range of cooking plates, gas or electric burners, to be completed with sink units and work surfaces.

Plan de travail en acier inoxydable personnalisable avec une large gamme de plaques de cuisson, feux à gaz ou électriques, à compléter avec évier et plans de travail.
Individuell gestaltbare Edelstahl-Arbeitsplatte mit einer großen Auswahl an Kochelementen, Gas- oder Elektroherden, ergänzbar durch Spülbecken und Arbeitsflächen.

COMPOSIZIONI TOP DISPONIBILI

AVAILABLE WORKTOP LAYOUTS | CONFIGURATIONS DES PLANS DISPONIBLES | VERFÜGBARE ARBEITSPLATTEN-KOMBINATIONEN



01

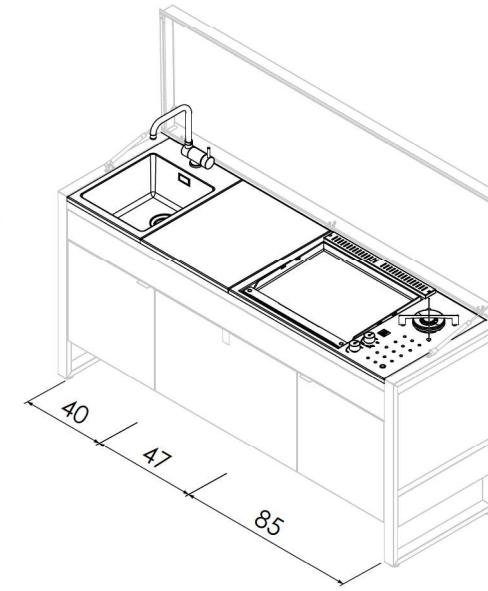

02

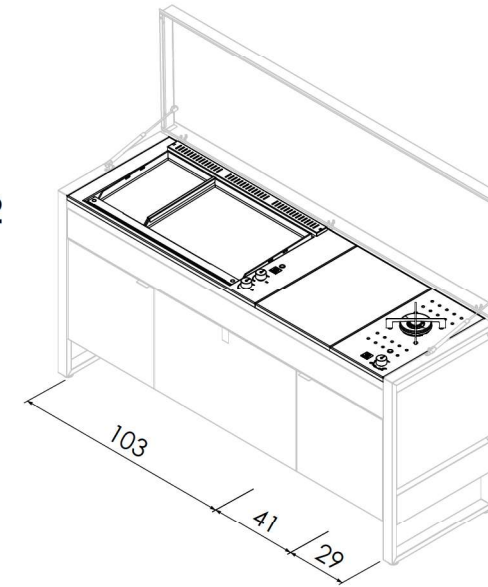

03

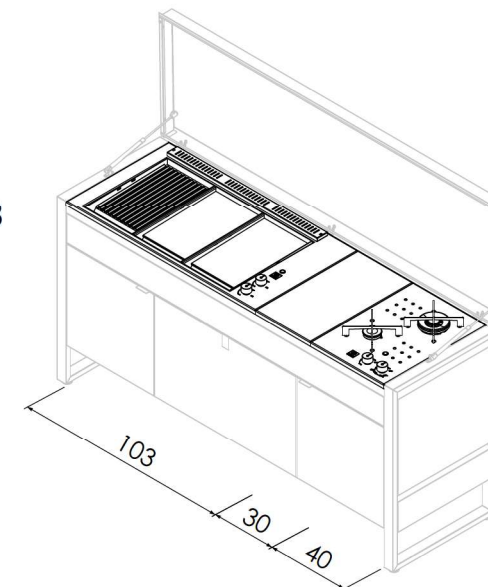

04

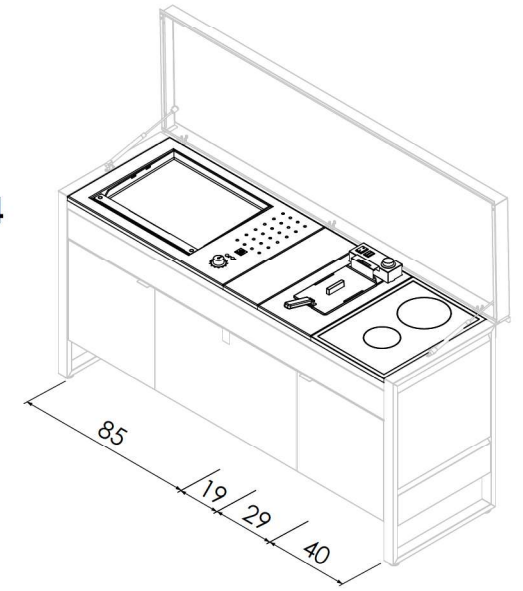

05

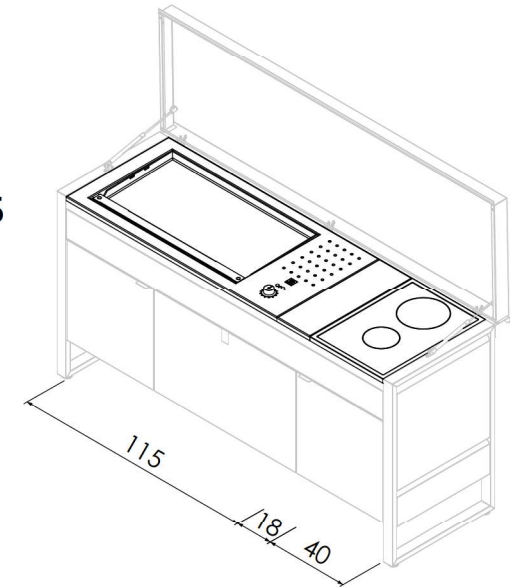

06

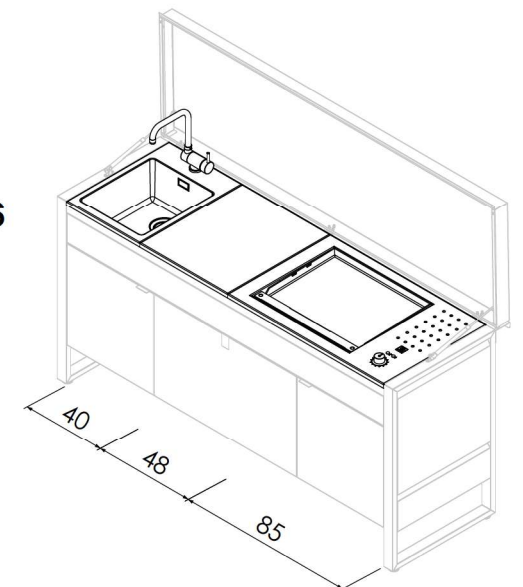

Kitchen
142.D
Finitura
Finitura / Finitura / Finitura
Inox PM
Madia
Sideboard / Buffet / Sideboard
M.150
Finitura
Finish / Finition / Ausführung
Textured Sand



OASI

142.D

L 142 x P 56+7 x H 87 cm

95 Kg



PIANO CUCINA: TOP COMPONENTE

KITCHEN WORKTOP: MODULAR WORKTOP | PLAN DE CUISINE: PLAN DE TRAVAIL MODULABLE | KÜCHENARBEITSPLATTE: MODULARE ARBEITSPLATTE

Coperchio e fascia in Inox verniciati Black o Moka
Lid and fascias in black or moka powder-coated stainless steel
Couvercle et bandeau en acier inoxydable thermolaqué noir ou moka
Deckel und Leisten aus Edelstahl, schwarz oder moka pulverbeschichtet

2 ante in Inox con Easy Stop e pannello centrale fisso
2 stainless steel doors with Easy-Stop system and fixed central panel
2 portes en acier inoxydable avec système Easy-Stop et panneau central fixe
2 Edelstahltüren mit Easy-Stop-System und festem Mittelpaneel

Gambe Inox con piedini regolabili, predisposti per utilizzo kit ruote
Stainless steel legs with adjustable feet, pre-drilled for wheel kit installation
Pieds en acier inoxydable avec patins réglables, prédisposés pour l'installation d'un kit de roues.
Edelstahlbeine mit verstellbaren Füßen, vorbereitet für die Montage eines Radsatzes



Top in Acciaio Inox personalizzabile con una vasta gamma di piani cottura, fornelli a gas o elettrici, da completare con lavello e piani di lavoro

Stainless steel worktop, customizable with a wide range of cooking plates, gas or electric burners, to be completed with sink units and work surfaces.

Plan de travail en acier inoxydable personnalisable avec une large gamme de plaques de cuisson, feux à gaz ou électriques, à compléter avec évier et plans de travail.

Individuell gestaltbare Edelstahl-Arbeitsplatte mit einer großen Auswahl an Kochelementen, Gas- oder Elektroherden, ergänzbar durch Spülbecken und Arbeitsflächen.

COMPOSIZIONI TOP DISPONIBILI

AVAILABLE WORKTOP LAYOUTS | CONFIGURATIONS DES PLANS DISPONIBLES | VERFÜGBARE ARBEITSPLATTEN-KOMBINATIONEN



01

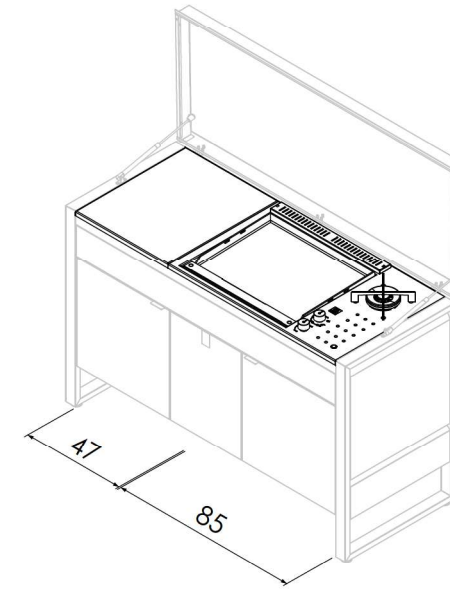

02

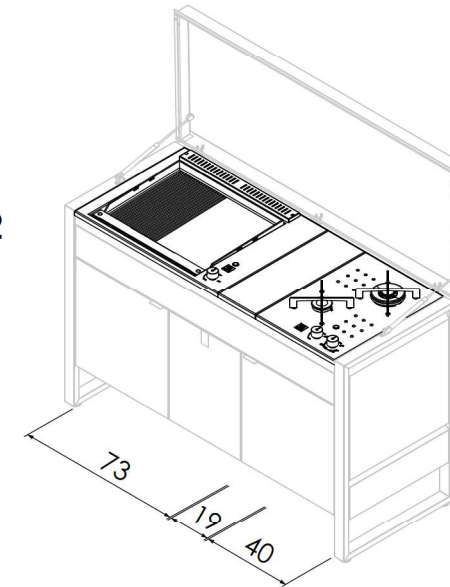

03

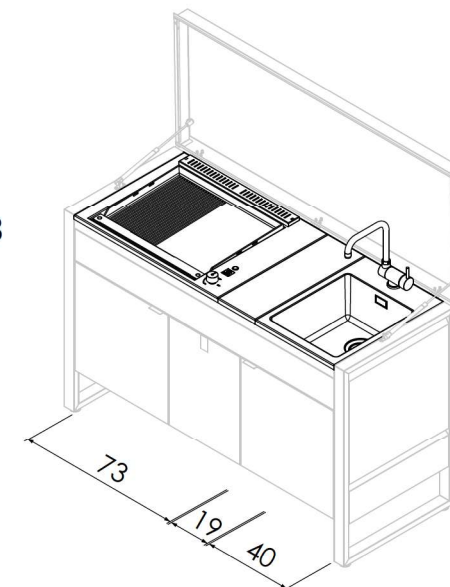

04

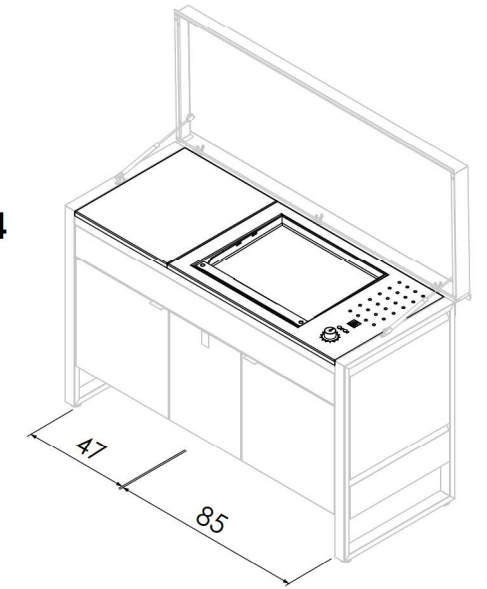

05

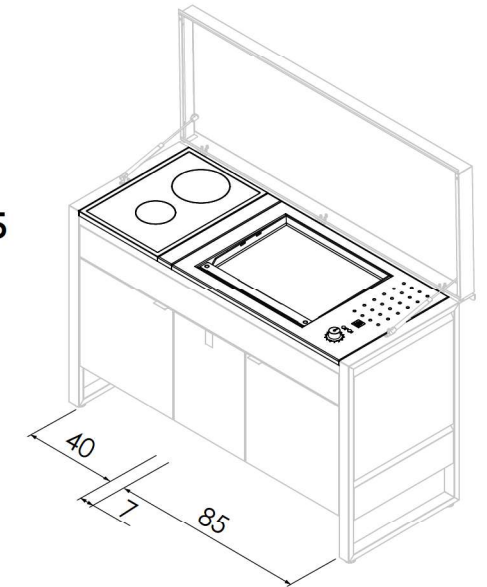

06

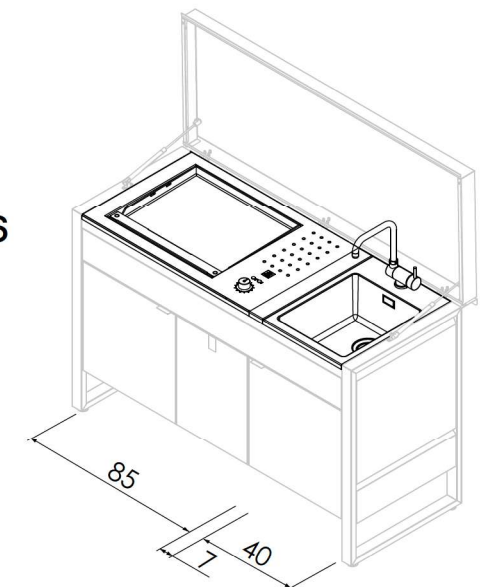

OASI

95.D

L 95 x P 56+7 x H 88 cm

80 Kg

Top personalizzabile con una vasta gamma di piani cottura, fornelli a gas o elettrici, da completare con lavello e piani di lavoro

A customizable worktop, configurable with a wide range of cooking plates, gas or electric burners, to be completed with sink units and work surfaces

Un plan de travail personnalisable avec une large gamme de plaques de cuisson, feux à gaz ou électriques, à compléter avec un évier et des plans de travail.

Eine individuell gestaltbare Arbeitsplatte mit einer großen Auswahl an Kochelementen, Gas- oder Elektroherden, ergänzbar durch Spülbecken und Arbeitsflächen.

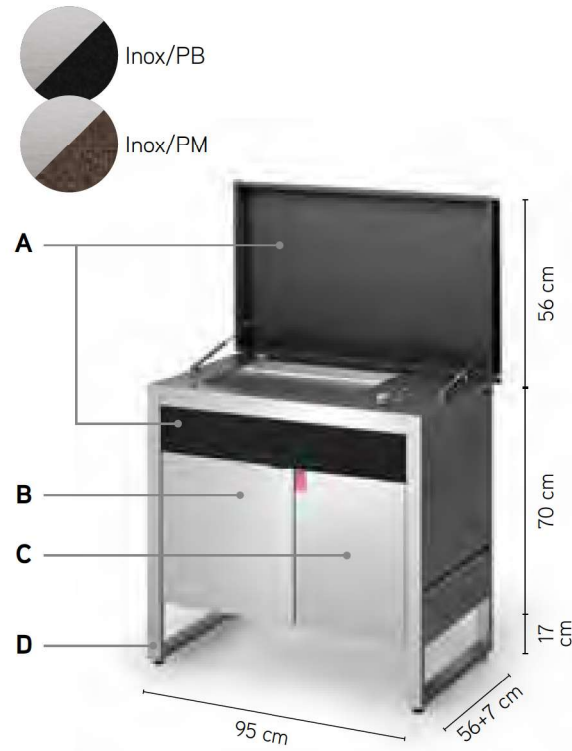

A. Coperchio e fascia in Inox verniciati Black o Moka
Lid and fascias in black or moka powder-coated stainless steel
Couvercle et bandeau en acier inoxydable thermolaqué noir ou moka
Deckel und Leisten aus Edelstahl, schwarz oder moka pulverbeschichtet

B. Anta in Inox con Easy Stop
Stainless steel door with Easy-Stop system
Porte en acier inoxydable avec système Easy-Stop
Edelstahltür mit Easy-Stop-System

C. Pannello fisso in Inox
Stainless steel fixed panel
Panneau fixe en acier inoxydable
Festes Edelstahlpaneel

D. Gambe Inox con piedini regolabili, predisposti per utilizzo kit ruote
Stainless steel legs with adjustable feet, pre-drilled for wheel kit installation
Pieds en acier inoxydable avec patins réglables, prédisposés pour l'installation d'un kit de roues.
Edelstahlbeine mit verstellbaren Füßen, vorgebohrt für die Montage eines Rollensatzes

E. Frigo da esterno con tre ripiani estraibili e vetro triplo strato (filtri UV)
Outdoor fridge with three removable shelves and triple-glass door
Réfrigérateur extérieur avec trois étagères amovibles et porte triple vitrage (filtres UV)
Außenkühlschrank mit drei herausnehmbaren Regalen und Dreifachglas-Tür (UV-Filter)

95.ICE

L 95 x P 56+7 x H 88 cm

80 Kg

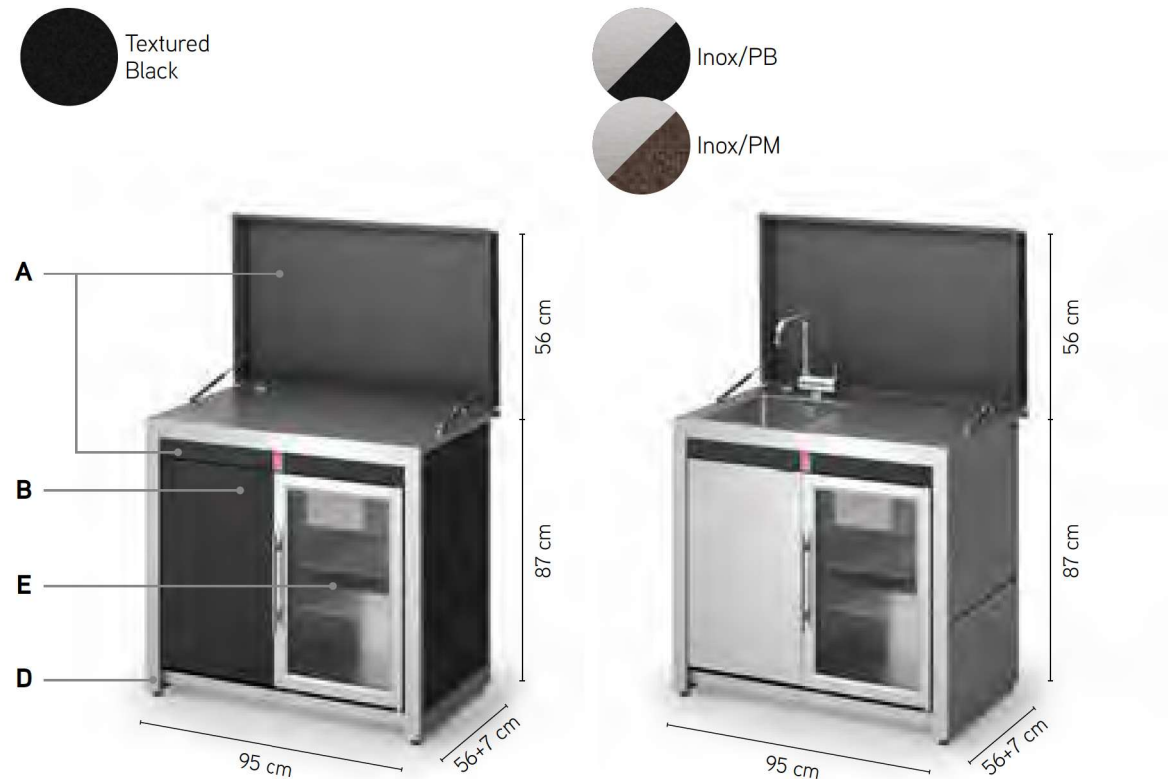

Textured Black

Inox/PB

Inox/PM

COMPOSIZIONI TOP DISPONIBILI

AVAILABLE WORKTOP LAYOUTS | CONFIGURATIONS DES PLANS DISPONIBLES | VERFÜGBARE ARBEITSPLETTEN-KOMBINATIONEN

GAS

ELECTRIC

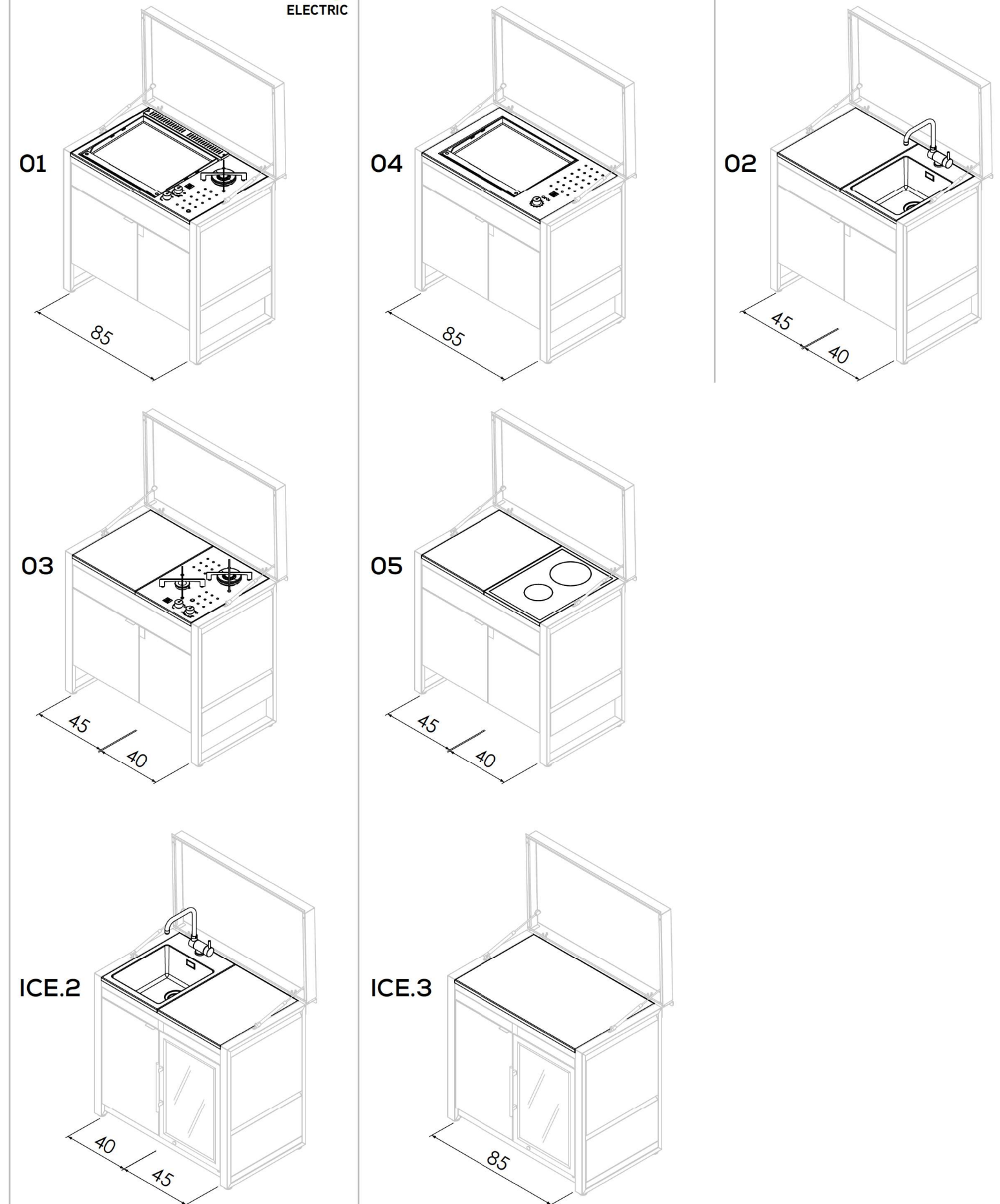

PIANO CUCINA: TOP COMPONENTI

KITCHEN COOKTOP: MODULAR WORKTOP | PLAN DE CUISINE: PLAN MODULAIRE | KÜCHENARBEITSPLATTE: MODULARES ARBEITSPLATTE

L 115 cm

Piastra cottura
Cooking plate / Plaque de cuisson / Kochplatte



B.IN 80 COMBI.L



B.IN 80 COMBI.LR



B.IN EL 80

L 103 cm

Piastra cottura
Cooking plate / Plaque de cuisson / Kochplatte



B.IN 80 L



B.IN 80 LR



B.IN 80 MIX.L



B.IN 80 MIX.LR



B.IN 80 GRILL.R/LL



B.IN 80 MIX GRILL.L

L 85 cm

Piastra cottura
Cooking plate / Plaque de cuisson / Kochplatte



B.IN 55 COMBI.L



B.IN 55 COMBI.LR



B.IN EL 55

L 73 cm

Piastra cottura
Cooking plate / Plaque de cuisson / Kochplatte



B.IN 55 L



B.IN 55 LR

L 59 cm

Fornello a gas
Gas stove / Réchaud à gaz / Gasherd

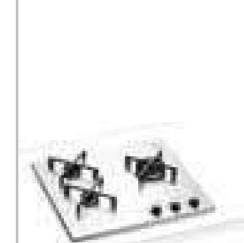

B.IN F3

L 40 cm

Fornello a gas
Gas stove / Réchaud à gaz / Gasherd



B.IN F2

Piano a induzione
Induction hob / Plaque à induction / Induktionskochfeld



B.IN INDU

Lavello
Sink / Évier / Spüle



B.IN LAV4056

L 29 cm

Fornello a gas
Gas stove / Réchaud à gaz / Gasherd



B.IN F1

Friggitrice
Fryer / Friteuse / Fritteuse



B.IN FR

Rubinetto miscelatore
abbattibile
Retractable Mixer Tap
Robinet Mélangeur pliable
faltbarer Spülbecken-Mischbatterie



SOTTO

SU MISURA CUSTOM-MADE

Piano di compensazione
Custom-sized worktop / Plan de travail sur mesure / Maß-Passplatte



Larghezza personalizzabile
Customizable width / Largeur personnalisable / Anpassbare Breite

ACCESSORI KITCHEN

KITCHEN ACCESSORIES | ACCESSOIRES DE CUISINE | KÜCHENZUBEHÖR

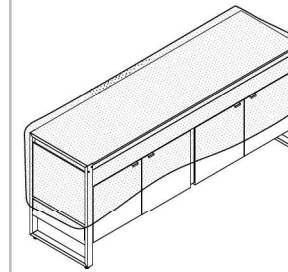

COVER

Copertura waterproof
Waterproof cover

L 246 cm **COVER 246**
L 205 cm **COVER 205**

L 183 cm **COVER 183**
L 142 cm **COVER 142**

L 95 cm **COVER 95**

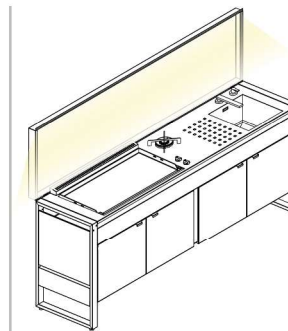

IN.LED

Barra led
LED light bar

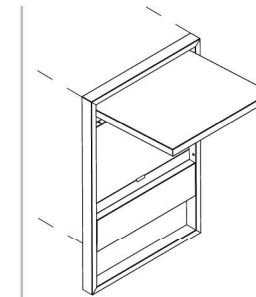

IN.FLAP

Mensola laterale pieghevole
Foldable side shelf

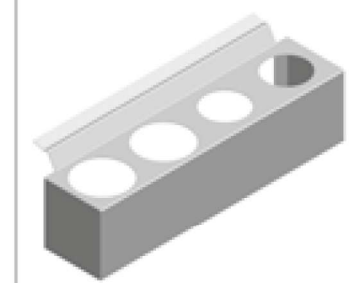

IN.CASE

Porta bottiglie laterale
Side bottle holder

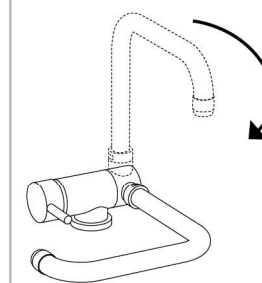

SOTTO

Rubinetto miscelatore abbattibile
Retractable Mixer Tap

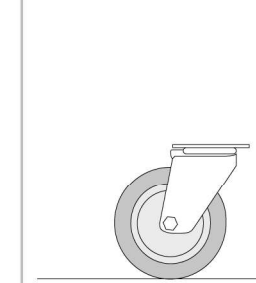

KIT 4WD

Kit ruote
Wheel kit